



CONSOLIDATED SEWING MACHINE CORP.

└ INDUSTRIAL SEWING & CUTTING EQUIPMENT

Model

206RB-5

Parts List

Intentionally left blank

INDEX 目次

	pages
面板、針板、糸調子.....	1,2
FACE PLATE, NEEDLE PLATE, THREAD TENSION	
上軸・天秤關係.....	3,4
ARM SHAFT, THREAD TAKE-UP LEVER	
針棒, 針棒土台, 上送り關係.....	5,6
NEEDLE BAR, NEEDLE BAR ROCK FRAME	
押え棒, 外押え.....	7,8
PRESSER BAR, LIFTING PRESSER FOOT	
送り關係.....	9,10
FEED MECHANISM	
送り調節關係.....	11,12
FEED REGULATOR	
立軸・下軸關係.....	13,14
ARM SHAFT, LOWER SHAFT	
給油關係.....	15,16
LUBRICATION	
付屬品關係.....	17,18
ACCESSORIES	
別売品.....	19,20
PARTS AVAILABLE AT EXTRA CHARGE	

THREAD TENSION, FACE PLATE, NEEDLE PLATE

糸調子, 針板

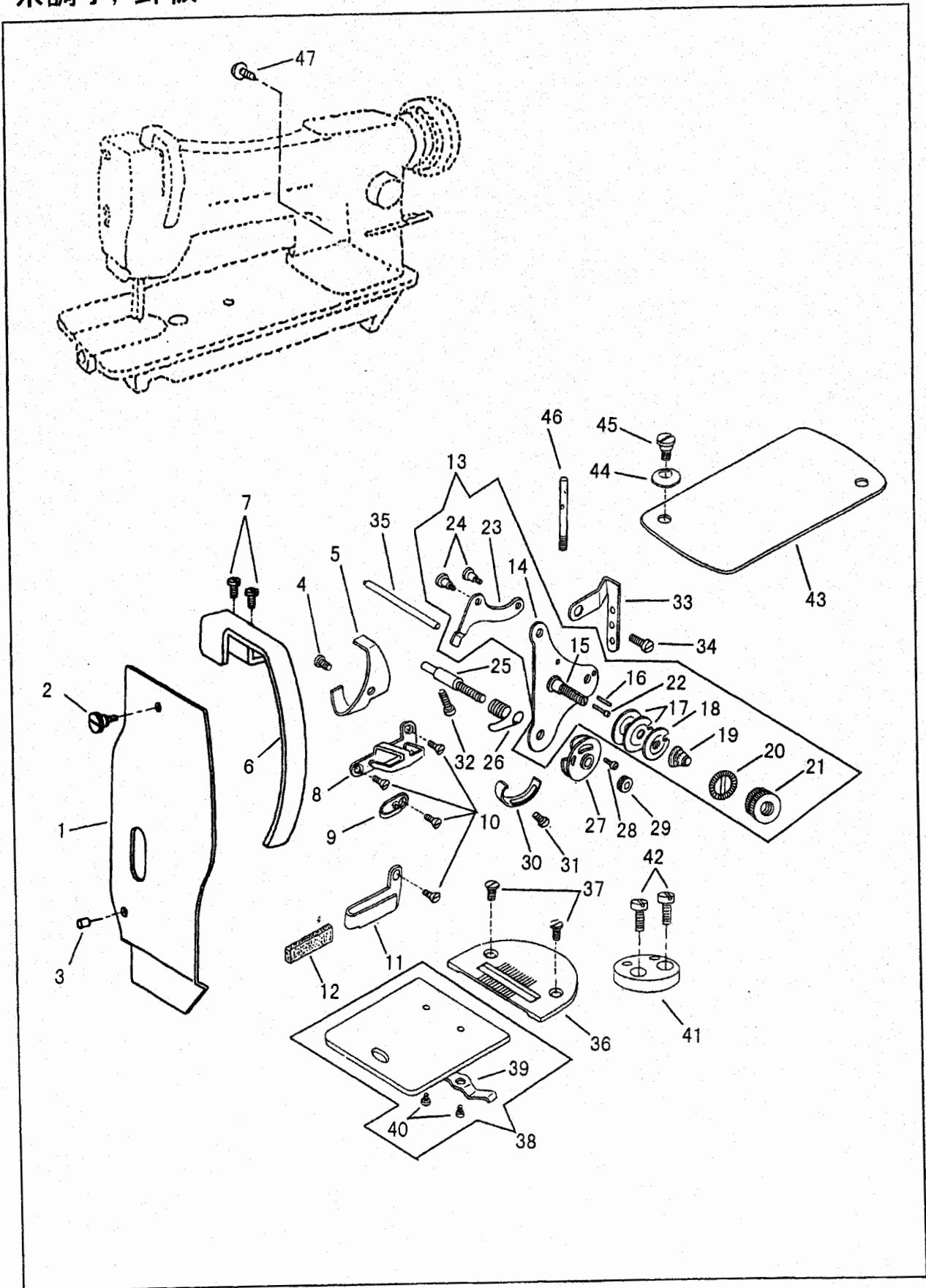

FACE PLATE, NEEDLE PLATE, THREAD TENSION
 面板, 針板, 糸調子

NO.	部品番号 PARTS NO.	STH-8BLD		数量 QTY	品名	PARTS NAME
		-3	-2			
1	19451	*		1	面板	FACE PLATE
2	8093	*	*	1	面板止めねじ	SCREW 9/64X40
3	10700	*	*	1	面板位置決めピン	POSITION PIN
4	3052	*		1	天秤油受止めねじ	SCREW 9/64X40 L=4.5
5	10551	*	*	1	天秤油受	OIL GUARD
6	19452	*		1	天秤カバー	TAKE-UP LEVER COVER
7	8040	*		2	天秤カバー止めねじ	SCREW 9/64X40 L=8.0
8	15054	*		1	面糸掛(上)	THREAD GUIDE (UPPER)
9	10683	*	*	1	面糸掛(中)	THREAD GUIDE (MIDDLE)
10	19510	*	*	4	面糸掛止めねじ	SCREW 9/64X40 L=6.5
11	10759-A	*	*	1	面糸掛(下)	THREAD GUIDE (LOWER)
12	10760	*	*	1	面糸掛フェルト	THREAD GUIDE FELT
13	19421C-A	*	*	1	調子板(組)	TENSION BRACKET COMPLETE
14	19421	*	*	1	調子板	TENSION BRACKET
15	19511	*	*	1	糸調子棒	TENSION STUD
16	10791	*	*	1	調子板ピン	TENSION BRACKET PIN
17	19531	*	*	2	調子皿	THREAD DISC
18	19532	*	*	1	丸皿	TENSION RELEASE WASHER
19	19533	*	*	1	渦巻スプリング	TENSION SPRING
20	28206	*	*	1	ローレットストッパー	TENSION THUMB NUT STOPPER
21	19513	*	*	1	ローレットナット	TENSION THUMB NUT
22	10793	*	*	1	糸ゆるめ段ピン	TENSION RELEASE PLUNGER
23	10678	*	*	1	糸ゆるめ板	TENSION RELEASE LEVER
24	19422	*	*	2	糸ゆるめ板段ねじ	SCREW 9/64X40
25	19512	*	*	1	糸調子棒	THREAD CONTROLLER STUD
26	10689	*	*	1	糸引きスプリング	THREAD CONTROLLER SPRING
27	10694	*	*	1	二重皿	THREAD CONTROLLER DISC
28	B118319	*	*	1	二重皿止めねじ	SCREW 3/32X56 L=6.0
29	19534	*	*	1	ローレットナット	TENSION THUMB NUT
30	10690	*	*	1	スプリング受	THREAD CONTROLLER SPRING STOP
31	8100	*	*	1	スプリング受止めねじ	SCREW 9/64X40 L=6.5
32	19518	*	*	1	糸調子棒止めねじ	SCREW 11/64X40 L=14.0
33	15062	*	*	1	大糸掛	THREAD RETAINER
34	18085	*	*	1	調子板止めねじ	SCREW 11/64X40 L=8.5
35	19501	*	*	1	糸ゆるめピン	TENSION RELEASE LEVER ROD
36	18030-S	*	*	1	針板	NEEDLE PLATE
37	6031-02	*		2	針板止めねじ	SCREW 11/64X40 L=8.5
38	18032C	*	*	1	角板(組)	BED SLIDE COMPLETE
39	6034	*	*	1	角板裏ばね	BED SLIDE SPRING
40	6035	*	*	2	角板裏ばね止めねじ	SCREW 3/32X56 L=2.7
41	18495	*	*	1	定規止板	EDGE GUIDE PLATE
42	37254	*	*	2	定規止板止めねじ	SCREW M4X0.7 L=8.0
43	19455	*		1	上板	ARM CAP
44	10703	*	*	1	上板止ワッシャー	WASHER
45	12384	*	*	1	上板段ねじ	SCREW 3/16X32
46	10709	*	*	1	糸立棒	SPOOL PIN SCREW 7/32X32
47	30046	*	*	1	アース線止めねじ	EARTH WIRE SCREW M4X0.7 L=4.0

ARM SHAFT, TAKE UP LEVER 上軸・天秤關係

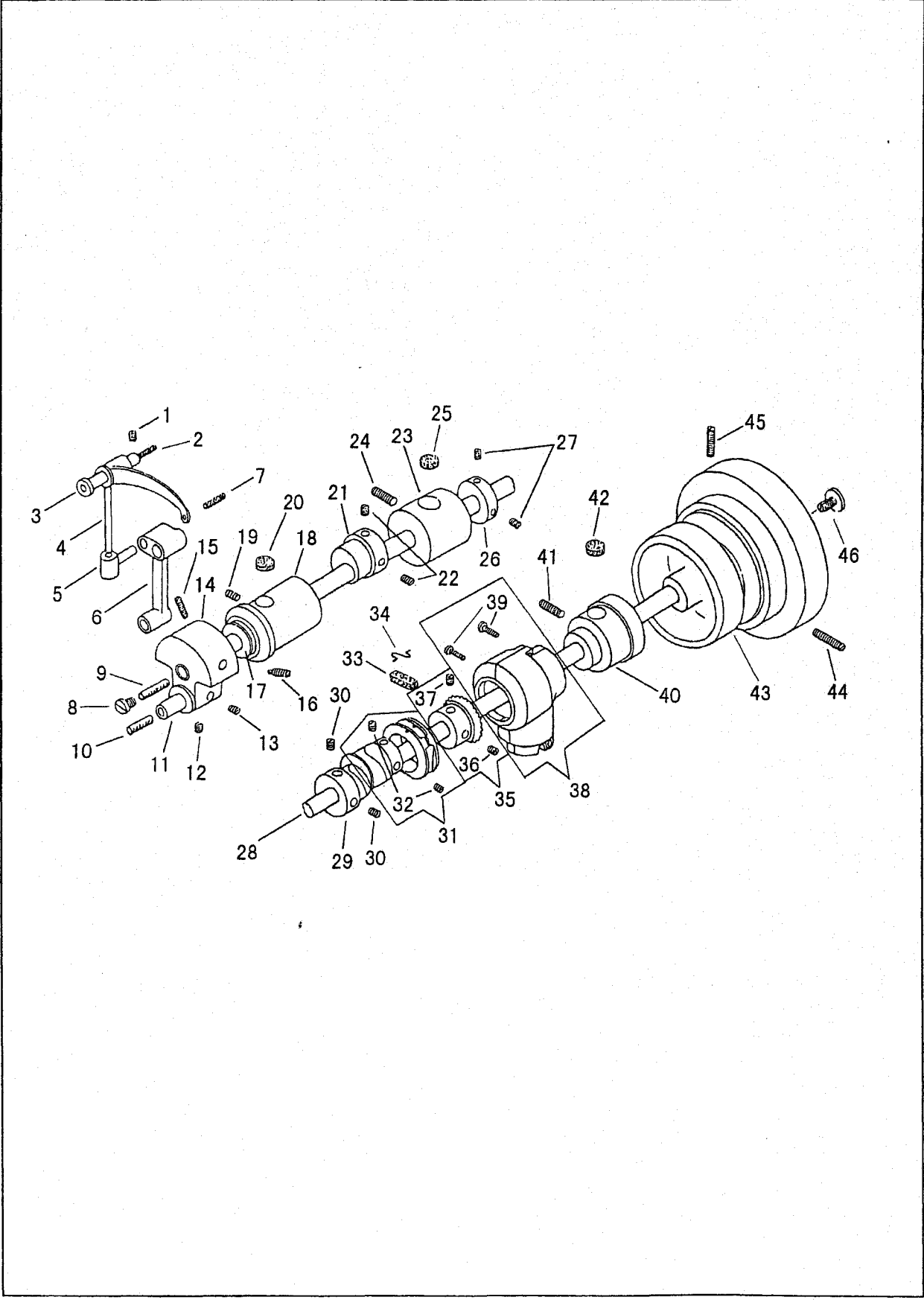

ARM SHAFT, THREAD TAKE-UP LEVER

上軸・天秤関係

NO.	部品番号 PARTS NO.	STH-8BLD		数量 QTY	品名	PARTS NAME
		-3	-2			
1	8009	*		1	天秤ピン止めねじ	SCREW 15/64X28 L=7.5
2	10724	*		1	天秤ピン油芯 6 X 6 X 180	OILING WICK
3	10527	*	*	1	天秤ピン	TAKE-UP LEVER HINGED STUD
4	18003	*	*	1	天秤	THREAD TAKE-UP LEVER
5	15026	*	*	1	天秤抱き	TAKE-UP LEVER DRIVING STUD
6	10528	*	*	1	針棒クランク	NEEDLE BAR CONNECTING LINK
7	10728	*	*	1	天秤抱き油芯 6 X 6 X 25	OILING WICK
8	19504	*	*	1	上軸油栓ねじ	OIL PACKING STOP SCREW 5/16X28 L=6.0
9	10724	*	*	1	上軸油芯 6 X 6 X 180	OILING WICK
10	10726	*	*	1	針棒クランクピン油芯 6 X 6 X 50	OILING WICK
11	10523	*	*	1	針棒クランクピン	NEEDLE BAR CONNECTING LINK STUD
12	19418	*	*	1	針棒クランクピン止めねじ(短)	SCREW 1/4X28 L=4.5
13	19417	*	*	1	針棒クランクピン止めねじ(長)	SCREW 1/4X28 L=6.5
14	19414	*	*	1	クランクモーションカム	NEEDLE BAR CRANK
15	19416	*	*	1	止めねじ	SET SCREW 1/4X28 L=14.0
16	19415	*	*	1	位置決めめじ	POSITION SCREW 1/4X28 L=20.0
17	10563	*	*	1	上軸メタル(前)ワッシャー	WASHER
18	18006	*	*	1	上軸メタル(前)	ARM SHAFT BUSHING (FRONT)
19	1786	*	*	1	上軸メタル(前)止めねじ	SCREW 15/64X28 L=12.0
20	10725	*	*	1	上軸メタル(前)フェルト	OILING FELT
21	18486	*	*	1	中押え上下カム	LIFTING ECCENTRIC
22	19508	*	*	2	中押え上下カム止めねじ	SCREW 1/4X40 L=5.5
23	18008	*	*	1	上軸メタル(中間)	ARM SHAFT BUSHING (MIDDLE)
24	10579	*	*	1	上軸メタル(中間)止めねじ	SCREW 15/64X28 L=20.0
25	10725	*	*	1	上軸メタル(中間)フェルト	OILING FELT
26	19506	*	*	1	上軸カラー	ARM SHAFT BUSHING COLLAR
27	23637	*	*	2	上軸カラー止めねじ	SCREW 1/4X28 L=7.5
28	19503	*	*	1	上軸	ARM SHAFT
29	19521	*	*	1	送り上下カム	FEED LIFTING CAM
30	10827	*	*	2	送り上下カム止めねじ	SCREW 1/4X40 L=7.5
31	19528C	*	*	1	送リカム(組)	FEED DRIVING ECCENTRIC COMPLETE
32	23637	*	*	2	送リカム止めねじ	SCREW 1/4X28 L=7.5
33	17041	*	*	1	ニ又リンクフェルト	OILING FELT
34	10723	*	*	1	ニ又リンクフェルト押え	OILING FELT RETAINER
35	17017C	*	*	1	上軸ギヤーねじ付	ARM SHAFT GEAR (SPIRAL) COMPLETE
36	17018	*	*	1	位置決めめじ	POSITION SCREW 1/4X40 L=8.0
37	17019	*	*	1	止めねじ	SET SCREW 1/4X40 L=7.5
38	17015C	*	*	1	ギヤーカバーセット(上)	GEAR COVER COMPLETE (UPPER)
39	17016	*	*	2	ギヤーカバー(上)締ねじ	SET SCREW 9/64X40 L=10.0
40	17013	*	*	1	上軸メタル(後)	ARM SHAFT BUSHING (REAR)
41	10579	*	*	1	上軸メタル(後)止めねじ	SCREW 15/64X28 L=20.0
42	13081	*	*	1	上軸メタル(後)フェルト	OILING FELT
43	18470	*	*	1	プーリー	BALANCE WHEEL
44	10576	*	*	1	位置決めめじ	POSITION SCREW 15/64X28 L=21.0
45	10579	*	*	1	止めねじ	SET SCREW 15/64X28 L=20.0
46	19505	*	*	1	プーリー押しねじ	SCREW 3/32X28 L=11.0

NEEDLE BAR, FEEDING MECHANISM 針棒・上送り関係

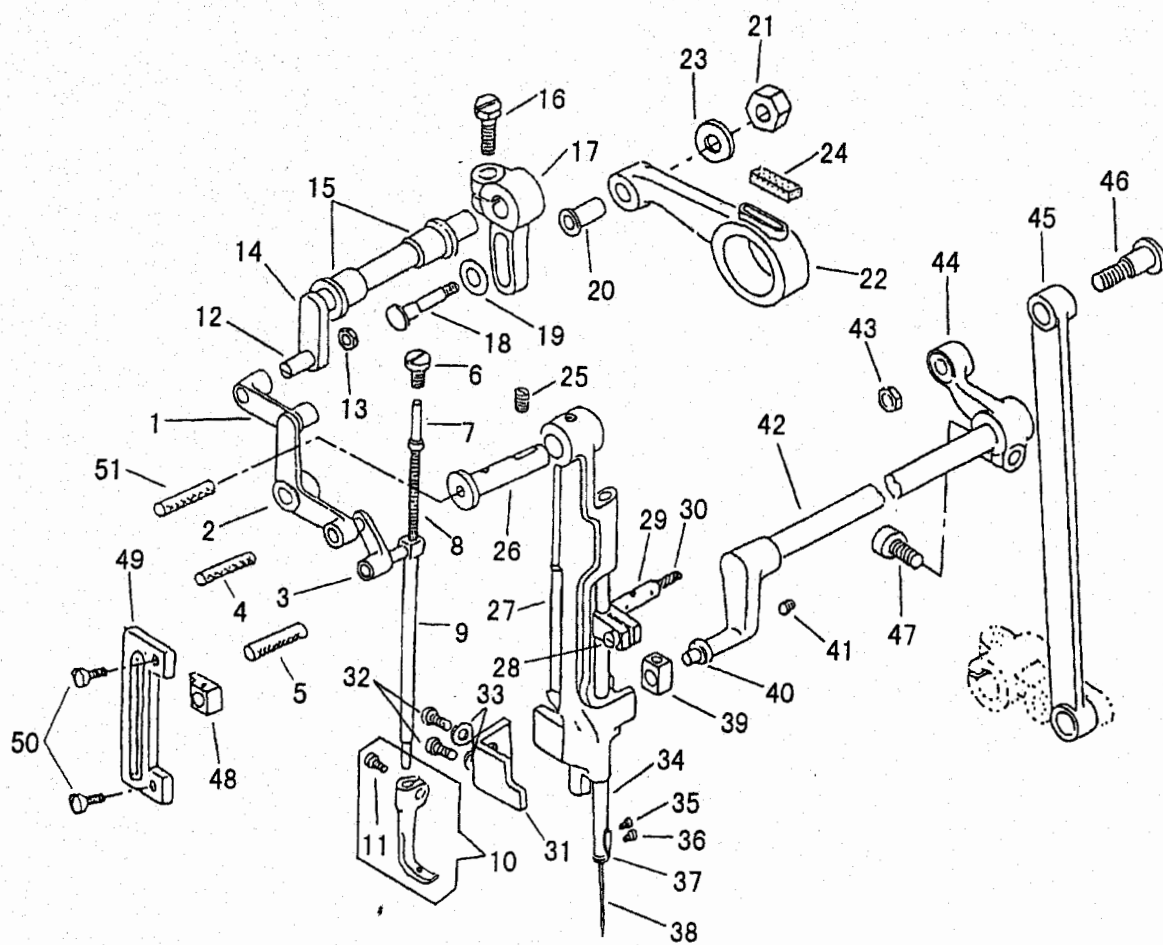

NEEDLE BAR, NEEDLE BAR ROCK FRAME
針棒・針棒土台・上送り関係

NO.	部品番号 PARTS NO.	STH-8BLD		QTY	品名	PARTS NAME
		-3	-2			
1	10557	*	*	1	くの字連結(大)	LIFTING BELL CRANK LINK
2	19509	*		1	くの字	LIFTING BELL CRANK
3	10556	*	*	1	くの字連結(小)	PRESSER BAR CONNECTING LINK
4	10728	*		1	くの字連結(小)油芯 6 X 6 X 25	OILING WICK
5	10728	*	*	1	中押え棒油芯 6 X 6 X 25	OILING WICK
6	19517	*	*	1	中押え棒押しねじ	SCREW 5/16X28 L=16.0
7	10553-A	*	*	1	中押えスプリング棒	VIBRATING PRESSER BAR EXTENSION
8	10554	*	*	1	中押えスプリング	PRESSER BAR EXTENSION SPRING
9	34713	*	*	1	中押え棒	VIBRATING PRESSER BAR
10	19412C	*	*	1	中押え(溝付)(ねじ付)組	VIBRATING PRESSER FOOT COMPLETE
11	17104	*	*	1	中押え締ねじ	PINCH SCREW 11/64X40 L=6.0
12	19515	*	*	1	横軸ピンねじ	HINGE SCREW 1/4X28
13	19516	*	*	1	横軸ピンねじナット	NUT 1/4X28
14	19514	*		1	横軸	LIFTING ROCK SHAFT
15	10514	*	*	2	横軸メタル	LIFTING ROCK SHAFT BUSHING
16	19420	*	*	1	上下カム連結だるま締ねじ	PINCH SCREW 1/4X28 L=16.0
17	19419	*	*	1	上下カム連結だるま	CONNECTING CRANK
18	10775	*	*	1	上連結ロッド段ねじ	HINGE SCREW 7/32X32
19	12136	*		1	上連結ロッド段ねじワッシャー	WASHER
20	10774	*	*	1	上連結ロッドパイプ	CONNECTING COLLAR
21	17114	*		1	上連結ロッド段ねじナット	NUT 7/32X32
22	18485	*		1	上連結ロッド	LIFTING ECCENTRIC CONNECTION
23	37215	*		1	上連結ロッド段ねじナットワッシャー	WASHER
24	17041	*		1	上連結ロッドフェルト	OILING FELT
25	100446	*	*	1	針棒土台ピン止めねじ	SCREW 15/64X28 L=8.8
26	34712	*		1	針棒土台ピン	HINGE STUD
27	17611	*		1	針棒土台	NEEDLE BAR ROCK FRAME
28	37134	*		1	針棒抱き締ねじ	PINCH SCREW M4X0.7 L=10.0
29	19426	*	*	1	針棒抱き	NEEDLE BAR CONNECTING STUD
30	19429	*		1	針棒抱き油芯 12 X 12 X 30	OILING WICK
31	34723	*		1	イケール	POSITION BRACKET
32	37134	*		2	イケール止めねじ	SCREW M4X0.7 L=10.0
33	30078	*		2	イケール止ワッシャ	WASHER
34	19413	*	*	1	針棒	NEEDLE BAR
35	6035	*		1	針棒糸掛け止めねじ	SCREW 3/32X56 L=2.7
36	B140553	*	*	1	針止めねじ	SCREW 1/8X40 L=4.5
37	10533	*	*	1	針棒糸掛	NEEDLE BAR THREAD GUIDE
38	N0122	*	*	1	針 DPX17 #22	NEEDLE DPX17 #22
39	11877	*	*	1	上送り竿角玉	SLIDE BLOCK
40	11876	*	*	1	上送り竿ピンねじ	HINGE SCREW 7/32X32
41	10581	*	*	1	上送り竿ピンねじ止めねじ	SCREW 7/32X32 L=7.0
42	17048	*	*	1	上送り竿	NEEDLE BAR ROCK FRAME ROCK SHAFT
43	6026-02	*	*	1	連結ロッド段ねじナット	NUT 9/32X28
44	19409	*	*	1	連結	CONNECTION
45	18017	*	*	1	連結ロッド	CONNECTION ROD
46	18018	*	*	1	連結ロッド段ねじ	HINGE SCREW 9/32X28
47	19408	*	*	1	連結締ねじ	PINCH SCREW 1/4X28 L=17.5
48	34722	*		1	振れ止角玉	VIBRATING PRESSER BAR BLOCK
49	34721	*		1	振れ止板	VIBRATING PRESSER BAR BLOCK GUIDE
50	8100	*	*	2	振れ止板止めねじ	SCREW 9/64X40 L=6.5
51	10728	*		1	針棒土台ピン油芯 6 X 6 X 25	OILING WICK

PRESSER BAR 押え関係

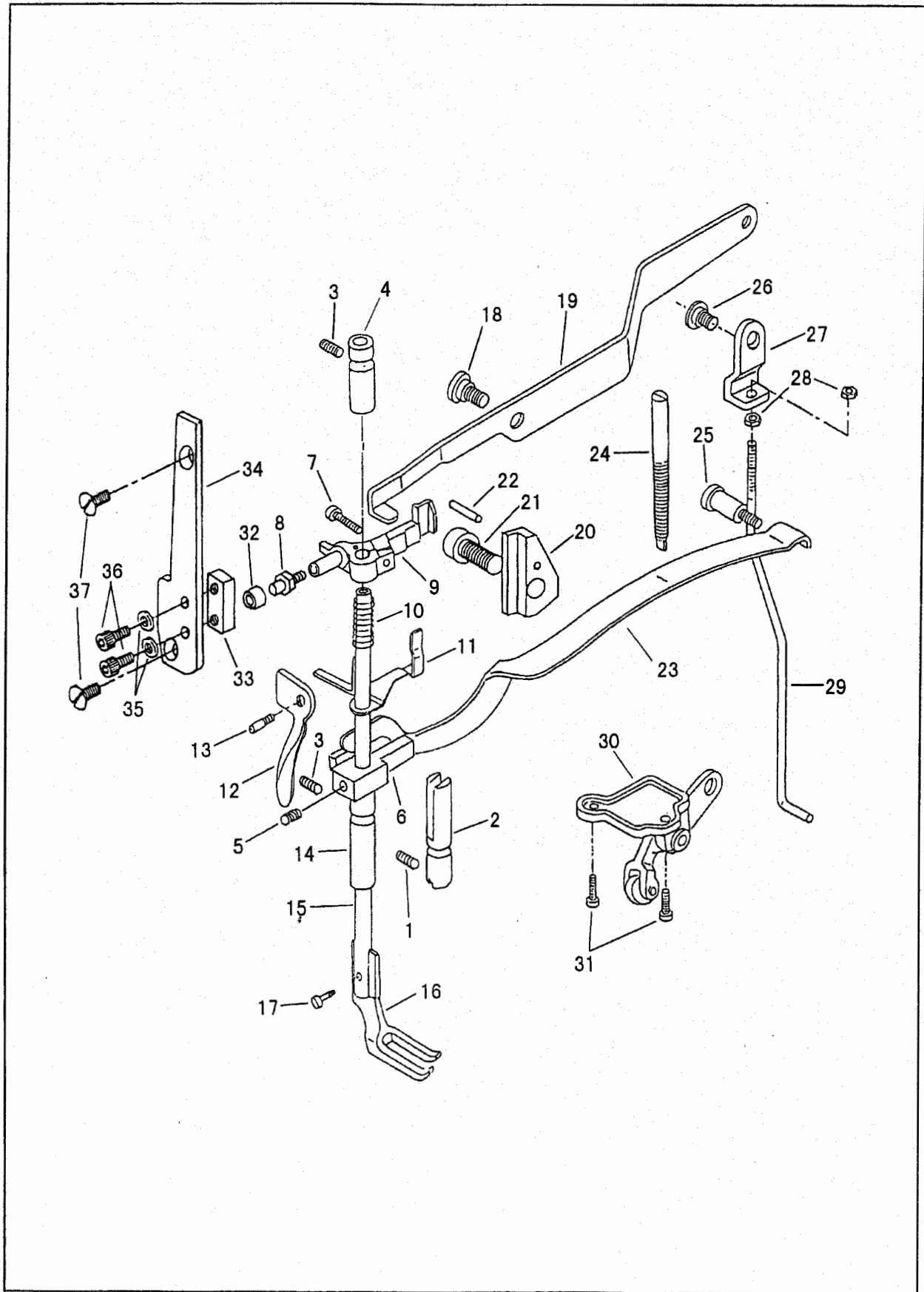

PRESSER BAR, LIFTING PRESSER FOOT
 押え棒・外押え

NO.	部品番号 PARTS NO.	STH-8BLD		QTY	品名	PARTS NAME
		-3	-2			
1	28043	*		1	案内棒止めねじ	SCREW M6X1 L=10.0
2	36729	*		1	案内棒	PRESSER BAR POSITION GUIDE
3	19406	*	*	2	押え棒メタル止めねじ	SCREW 15/64X28 L=11.0
4	10538	*	*	1	押え棒メタル(上)	PRESSER BAR BUSHING (UPPER)
5	35999	*		1	押え棒案内締ねじ	SCREW M6X1 L=6.0
6	18478	*		1	押え棒案内	PRESSER BAR POSITION GUIDE BRACKET
7	19518	*	*	1	押え棒抱き締ねじ	PINCH SCREW 11/64X40 L=14.0
8	34828	*		1	くの字案内ピンねじ	SCREW 11/64X40
9	18479	*	*	1	押え棒抱き	PRESSER BAR LIFTING BRACKET
10	10547	*	*	1	押え棒抱き下板ばね	SPRING
11	10546-A	*	*	1	押え棒抱き下板	TENSION RELEASE SLIDE
12	10659	*	*	1	押え上げレバー	PRESSER BAR LIFTER
13	19405	*	*	1	レバーピンねじ	HINGE SCREW 3/16X32
14	18085	*	*	2	大砲止めねじ	SCREW 11/64X40 L=8.5
15	18477	*		1	押え棒	PRESSER BAR
16	10796	*	*	1	外押え	LIFTING PRESSER FOOT
17	18483	*		1	外押え止めねじ	SCREW 9/64X40 L=9.0
18	19403	*	*	1	弓止めねじ	HINGE SCREW 1/4X28
19	18080	*	*	1	弓	KNEE LIFTER LIFTING LEVER
20	10548-A	*	*	1	押え棒抱き振れ止台	BRACKET GUIDE BLOCK
21	19408	*	*	1	振れ止台止めねじ	PINCH SCREW 1/4X28 L=17.5
22	15111	*	*	1	振れ止台ピン	PIN
23	36026	*		1	押え棒大板ばね	PRESSER BAR SPRING
24	19519	*	*	1	大板ばね調節ねじ	PRESSER BAR SPRING REGULATING SCREW 1/4X28
25	19404	*	*	1	大板ばね受ねじ	PRESSER BAR SPRING SUPPORT SCREW 1/4X28
26	6384	*	*	1	吊り棒だるま段ねじ	HINGE SCREW 15/64X28
27	6359-A	*	*	1	吊り棒だるま	LIFTING LEVER CONNECTING ROD JOINT
28	6360	*	*	2	吊り棒ナット	NUT 3/16X32
29	18081	*	*	1	吊り棒	LIFTING LEVER CONNECTING ROD
30	18862	*	*	1	大砲セット	KNEE LIFTER BELL CRANK COMPLETE
31	10539-A	*		1	押え棒メタル(下)	PRESSER BAR BUSHING (LOWER)
32	34717	*		1	くの字案内カラー	LIFTING BELL CRANK GUIDE COLLAR
33	34718	*		1	くの字案内駒	LIFTING BELL CRANK GUIDE BLOCK
34	34719	*		1	くの字案内板	LIFTING BELL CRANK GUIDE PLATE
35	16287	*		2	くの字案内駒止ワッシャー	WASHER
36	30601	*		2	くの字案内駒止めねじ	SCREW M5X0.8 L=10.0
37	34720	*		2	くの字案内板止めねじ	SCREW M6X1 L=12.0

LOWER FEEDING MECHANISM 下送り関係

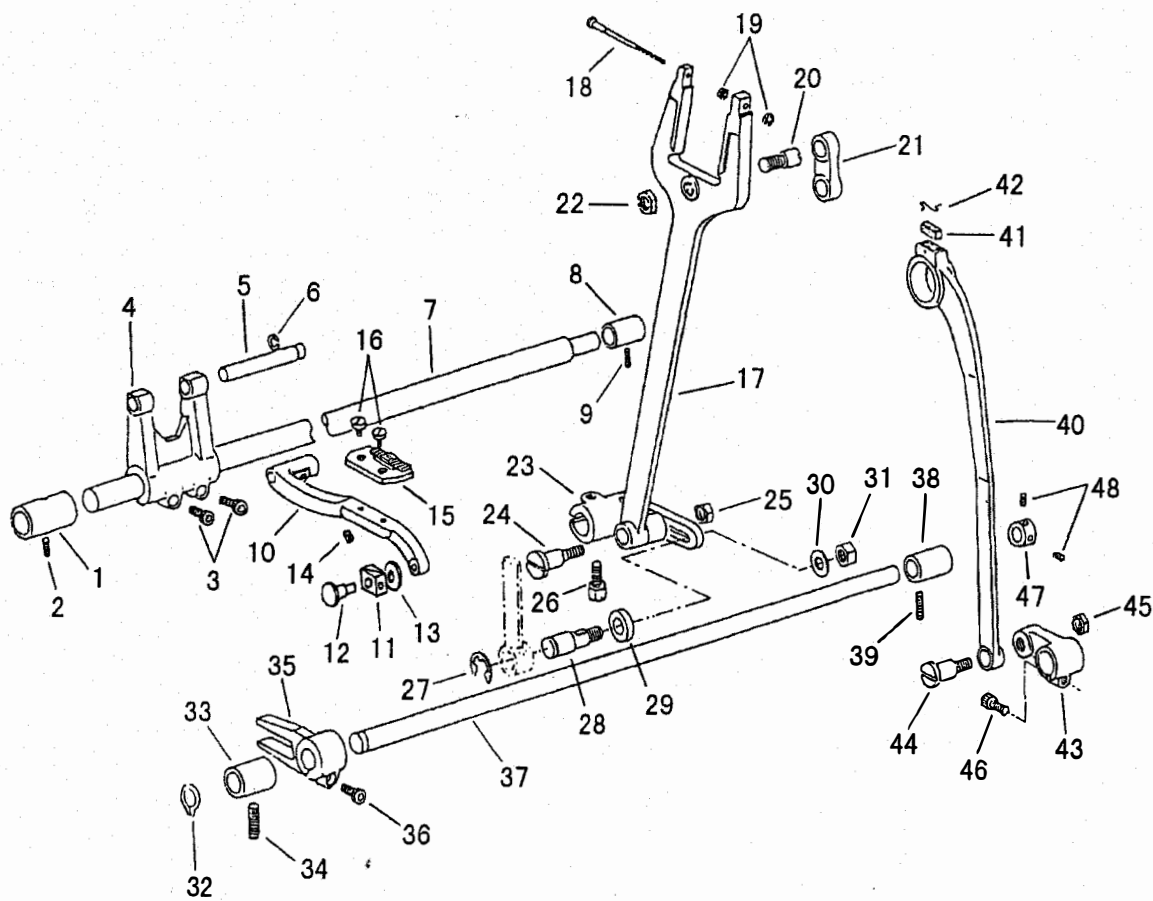

FEED MECHANISM

下送り関係

NO.	部品番号 PARTS NO.	STH-8BLD		QTY	品名	PARTS NAME
		-3	-2			
1	18523	*	*	1	送り軸メタル(前)	FEED ROCK SHAFT BUSHING (FRONT)
2	8009	*	*	1	止めねじ	SCREW 15/64X28 L=7.5
3	18065	*	*	2	送り腕締ねじ	PINCH SCREW M5X0.8 L=14.0
4	18694	*	*	1	送り腕	FEED ROCK SHAFT BASE
5	18696	*	*	1	送り土台受ピン	FEED BASE SUPPORTING PIN
6	31094	*	*	1	送り土台受ピン止め輪	"E" RING
7	18061	*	*	1	送り軸	FEED ROCK SHAFT
8	18702	*	*	1	送り軸メタル(後)	FEED ROCK SHAFT BUSHING (BACK)
9	8009	*	*	1	止めねじ	SCREW 15/64X28 L=7.5
10	19526	*	*	1	送り土台	FEED BASE
11	19535	*	*	1	送り土台角玉	FEED BAR SLIDE BLOCK
12	19529	*	*	1	送り土台角玉ピン	SLIDE BLOCK PIN
13	19530	*	*	1	送り土台角玉ワッシャー	WASHER
14	50230	*	*	1	送り土台止めねじ	SCREW 3/16X32 L=5.0
15	18031	*	*	1	送り歯	FEED DOG
16	19525	*	*	2	止めねじ	SCREW 1/8X40 L=6.0
17	18122	*	*	1	二又ロッド	FEED FORKED CONNECTION
18	18121	*	*	1	二又ロッド補助ねじ	HINGE SCREW M3X0.5
19	4211	*	*	2	二又ロッド補助ねじナット(小)	NUT M3X0.5 (SMALL)
20	18014	*	*	1	二又ロッドピンねじ	HINGE SCREW 9/32X28
21	17207	*	*	1	メガネリンク	FEED CONNECTING LINK
22	8105	*	*	1	二又ロッドピンねじナット	NUT 9/32X28
23	19527	*	*	1	送り軸だるま(後)	FEED ROCK SHAFT CRANK (BACK)
24	18015	*	*	1	二又ロッド段ねじ	HINGE SCREW 9/32X28
25	8105	*	*	1	二又ロッド段ねじナット	NUT 9/32X28
26	31021	*	*	1	送り軸後だるま締ねじ	PINCH SCREW M6X1 L=16.0
27	17095	*	*	1	送り軸ピンねじ止め輪	"E" RING
28	18539	*	*	1	送り軸後だるまピンねじ	HINGE SCREW M6X1
29	18540	*	*	1	送り軸ピンねじワッシャー	WASHER
30	10599	*	*	1	送り軸後だるまピンねじワッシャー	WASHER
31	11412	*	*	1	送り軸後だるまピンねじナット	NUT M6X1
32	18490	*	*	1	上下送り軸止め輪	RETAINING RING
33	18489	*	*	1	上下送り軸メタル(前)	FEED LIFTING ROCK SHAFT BUSHING(FRONT)
34	8009	*	*	1	止めねじ	SCREW 15/64X28 L=7.5
35	18492	*	*	1	上下送り軸だるま(前)	FEED LIFTING CRANK (FRONT)
36	30066	*	*	1	上下送り軸だるま(前)締ねじ	PINCH SCREW M5X0.8 L=12.0
37	18488	*	*	1	上下送り軸	FEED LIFTING ROCK SHAFT
38	18489	*	*	1	上下送り軸メタル(後)	FEED LIFTING ROCK SHAFT BUSHING (BACK)
39	8009	*	*	1	止めねじ	SCREW 15/64X28 L=7.5
40	18021	*	*	1	上下ロッド	CRANK CONNECTING ROD
41	17041	*	*	1	上下ロッドフェルト	OILING FELT
42	10723	*	*	1	上下ロッドフェルト押え	RETAINER
43	18493	*	*	1	上下送り軸だるま(後)	FEED LIFTING CRANK (BACK)
44	18018	*	*	1	上下送り軸ロッド段ねじ	HINGE SCREW 9/32X28
45	8105	*	*	1	上下送り軸ロッド段ねじナット	NUT 9/32X28
46	18065	*	*	1	上下送り軸だるま(後)締ねじ	PINCH SCREW M5X0.8 L=14.0
47	18491	*	*	1	上下送り軸カラー	LIFTING SHAFT COLLAR
48	19508	*	*	2	止めねじ	SCREW 1/4X40 L=5.5

FEED REGULATOR 送り調節関係

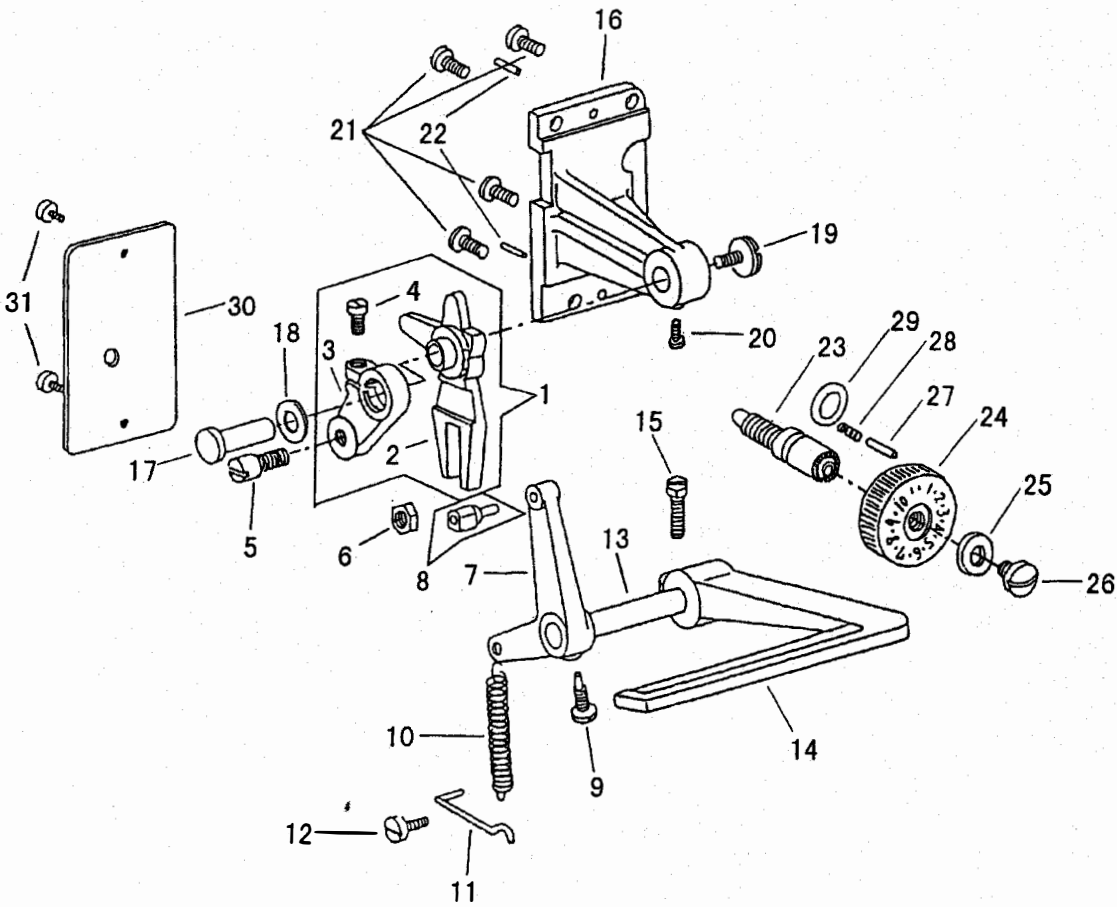

FEED REGULATOR

送り調節関係

NO.	部品番号 PARTS NO.	STH-8BLD		QTY	品名	PARTS NAME
		-3	-2			
1	19542C	*		1	送り調節(組)	FEED REGULATOR COMPLETE
2	19542	*		1	送り調節	FEED REGULATOR
3	19524	*		1	送り調節ロッド	FEED REGULATOR ROD
4	37134	*		1	送り調節ロッド締めねじ	PINCH SCREW M4X0.7 L=10.0
5	17209	*	*	1	送り調節ピンねじ	FEED REGULATOR SCREW 9/32X28
6	8105	*	*	1	送り調節ピンねじナット	NUT 9/32X28
7	18506	*	*	1	バックレバー軸だるま	REVERSE LEVER SHAFT CRANK
8	18721C	*	*	1	バック角玉組(ピン付き)	REVERSE BLOCK COMPLETE
9	18507	*	*	1	バックレバー軸だるま止めねじ	SCREW 15/64X28
10	18515	*	*	1	バックレバーコイルスプリング	REVERSE LEVER SPRING
11	18516	*	*	1	バックレバーコイルスプリング掛け	SPRING RETAINER
12	7033	*	*	1	止めねじ	SCREW 9/64X40 L=10.8
13	18574	*		1	バックレバー軸	REVERSE LEVER SHAFT
14	19544	*		1	バックレバー	REVERSE LEVER
15	10845	*	*	1	バックレバー締めねじ	PINCH SCREW 15/64X28 L=18.0
16	19546	*		1	送り調節台	FEED REGULATING BASE
17	18494	*		1	送り調節支持ピン	FEED REGULATING SUPPORT STUD
18	17057	*	*	1	送り調節ワッシャー	WASHER
19	1392	*		1	送り調節支持ピン押しねじ	SCREW 11/64X40 L=6.5
20	19552	*		1	送り調節支持ピン止めねじ	SCREW 11/64X28 L=11.5
21	30066	*	*	4	送り調節台止めねじ	SCREW M5X0.8 L=12.0
22	50174	*	*	2	送り調節台ノックピン	POSITION PIN
23	19523	*		1	送り調節ねじ	FEED REGULATING SCREW
24	18496	*		1	送り調節ダイヤル	FEED REGULATING DIAL
25	B142746	*		1	ダイヤル座金	WASHER
26	19522	*		1	止めねじ	SCREW 3/16X32 L=20.0
27	B145502	*		1	送り調節ダイヤルピン	PIN
28	B100328	*		1	送り調節ダイヤルコイルスプリング	SPRING
29	18420	*	*	1	Oリング	O RING
30	19543	*		1	アーム横カバー	ARM SIDE COVER
31	37509	*		2	アーム横カバー止めねじ	SCREW M5X0.8 L=6.0

ARM SHAFT(UPRIGHT)、LOWER SHAFT 立軸・下軸関係

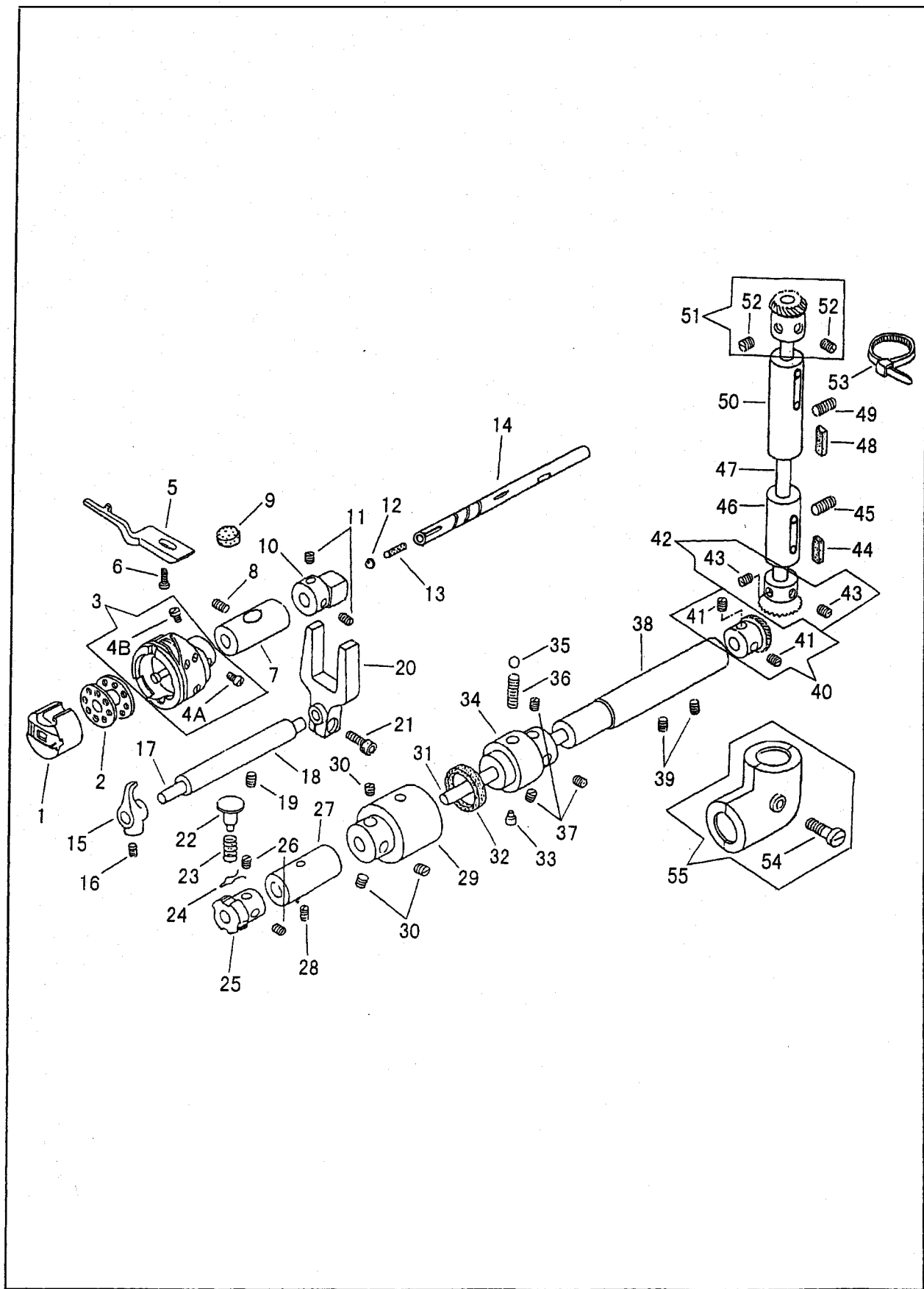

From the library of: Diamond Needle Corp

ARM SHAFT(UPRIGHT), LOWER SHAFT
立軸・下軸関係

NO.	部品番号 PARTS NO.	STH-8BLD		QTY	品名	PARTS NAME
		-3	-2			
1	18096	*	*	1	ボビンケースセット	BOBBIN CASE COMPLETE
2	18034	*	*	1	ボビン	BOBBIN
3	18033C	*	*	1	カマセット	ROTATING HOOK COMPLETE
4A	18033-07	*	*	1	位置決めねじ	POSITION SCREW 11/64X40 L=8.9
4B	18033-08	*	*	1	止めねじ	SET SCREW 11/64X40 L=7.3
5	18035	*	*	1	カマ受	HOOK SUPPORTING PLATE
6	6025	*	*	1	カマ受止めねじ	SCREW 11/64X40 L=12.0
7	18090	*	*	1	カマ軸メタル(前)	HOOK SHAFT BUSHING (FRONT)
8	8009	*	*	1	カマ軸メタル(前)止めねじ	SCREW 15/64X28 L=7.5
9	11069	*	*	1	フェルト	OILING FELT
10	18044	*	*	1	オープナーカム	HOOK SHAFT CAM
11	8009	*	*	2	止めねじ	SCREW 15/64X28 L=7.5
12	18351	*	*	1	カマ軸油栓座金	WASHER
13	0148-B	*	*	1	カマ軸フェルト φ3 X 15	OILING FELT
14	18089	*	*	1	カマ軸	HOOK DRIVING SHAFT
15	18039	*	*	1	ボビンケースオープナー	THREAD RELEASING FINGER
16	18040	*	*	1	オープナー止めねじ	SCREW M5X0.8 L=8.0
17	18041	*	*	1	オープナー軸	THREAD RELEASING SHAFT
18	18042	*	*	1	オープナー軸メタル	THREAD RELEASING SHAFT BUSHING
19	8009	*	*	1	メタル止めねじ	SCREW 15/64X28 L=7.5
20	18043	*	*	1	オープナーニ又	THREAD RELEASING SHAFT FORK
21	30066	*	*	1	オープナーニ又締めねじ	PINCH SCREW M5X0.8 L=12.0
22	18053	*	*	1	押しボタン	PUSH BUTTON
23	18054	*	*	1	押しボタンスプリング	PUSH BUTTON SPRING
24	10674	*	*	1	押しボタン止ピン	CLIP
25	18052	*	*	1	溝車	HOOK SHAFT LOCK RATCHET
26	19508	*	*	2	溝車止めねじ	SCREW 1/4X40 L=5.0
27	18038-A	*	*	1	カマ軸メタル(後)	HOOK SHAFT BUSHING (REAR)
28	8009	*	*	1	メタル(後)止めねじ	SCREW 15/64X28 L=7.5
29	18047	*	*	1	クラッチ(左)	SAFETY CLUTCH (LEFT)
30	17019	*	*	3	クラッチ(左)止めねじ	SCREW 1/4X40 L=7.5
31	18056	*	*	1	下軸	LOWER SHAFT
32	18046	*	*	1	クラッチ油芯 6 X 6 X 80	OILING WICK
33	18051	*	*	1	クラッチスプリング止めねじ	SCREW 9/32X28
34	18048	*	*	1	クラッチ(右)	SAFETY CLUTCH (RIGHT)
35	18049	*	*	1	クラッチ鋼球	STEEL BALL
36	18050	*	*	1	クラッチスプリング	SPRING
37	17019	*	*	3	クラッチ(右)止めねじ	SCREW 1/4X40 L=7.5
38	18057	*	*	1	下軸メタル	LOWER SHAFT BUSHING
39	8009	*	*	2	メタル止めねじ	SCREW 15/64X28 L=7.5
40	17028C	*	*	1	下軸ギヤー(ねじ付)	LOWER SHAFT GEAR (SPIRAL) COMPLETE
41	17022	*	*	2	下軸ギヤー止めねじ	SET SCREW 1/4X40 L=5.0
42	17023C	*	*	1	立軸ギヤー(下)(ねじ付)	ARM SHAFT (UPRIGHT) GEAR (LOWER)(SPIRAL)COMPLETE
43	17022	*	*	2	立軸ギヤー(下)止めねじ	SET SCREW 1/4X40 L=5.0
44	17026	*	*	1	立軸下メタルフェルト	OILING FELT
45	10579	*	*	1	メタル(下)止めねじ	SET SCREW 15/64X28 L=20.0
46	19553	*	*	1	立軸メタル(下)	ARM SHAFT (UPRIGHT) BUSHING (LOWER)
47	17020	*	*	1	立軸	ARM SHAFT (UPRIGHT)
48	17026	*	*	1	立軸メタル(上)フェルト	OILING FELT
49	10579	*	*	1	メタル(上)止めねじ	SCREW 15/64X28 L=20.0
50	19554	*	*	1	立軸メタル(上)	ARM SHAFT (UPRIGHT) BUSHING (UPPER)
51	17021C	*	*	1	立軸ギヤー(上)(ねじ付)	ARM SHAFT (UPRIGHT) GEAR (SPIRAL) COMPLETE
52	17022	*	*	2	立軸ギヤー(上)止めねじ	SET SCREW 1/4X40 L=5.0
53	30750	*	*	1	立軸メタル(上)バンド	BAND
54	18058C	*	*	1	ギヤーカバー(下)(ねじ付)	GEAR COVER (LOWER) (SPIRAL) COMPLETE
55	18059	*	*	1	ギヤーカバー(下)締めねじ	PINCH SCREW 15/64X28 L=26

LUBRICATION 自動給油關係

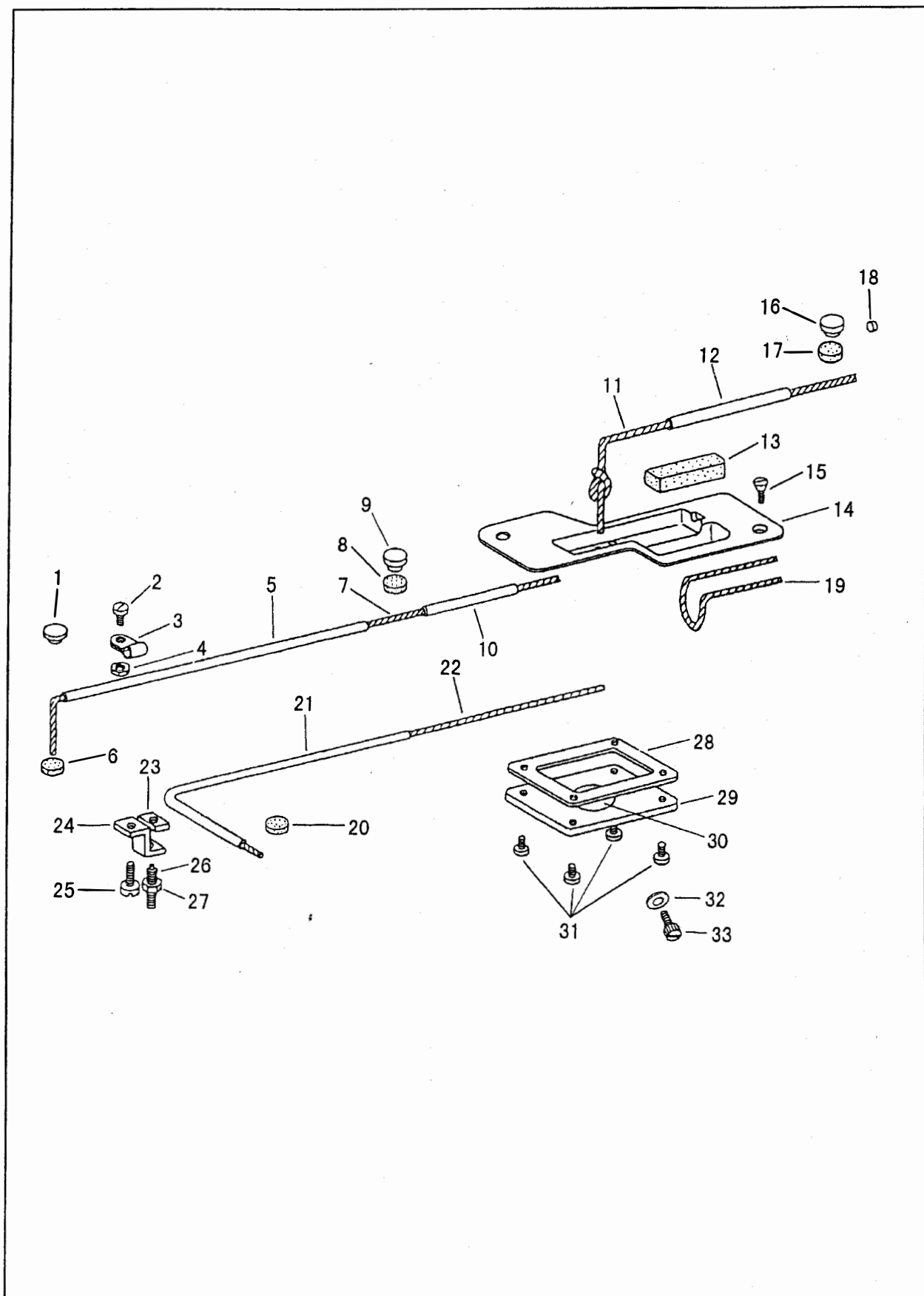

From the library of: Diamond Needle Corp

LUBRICATION
給油関係

NO.	部品番号 PARTS NO.	STH-8BLD		QTY	品名	PARTS NAME
		-3	-2			
1	20171	*	*	1	上軸メタル(前)ゴム栓	RUBBER PLUG
2	4124	*	*	1	油芯止めねじ	SCREW M4X0.7 L=9.5
3	30022	*	*	1	油芯止クランプ	OILING WICK CLAMP
4	31206	*	*	1	油芯止ナット	NUT
5	18112	*	*	1	ビニールチューブ	OIL TUBE 160MM
6	11069	*	*	1	上軸メタル(前)フェルト	OILING FELT
7	18110	*	*	1	油芯	OILING WICK 380MM
8	11069	*	*	1	上軸メタル(中間)フェルト	OILING FELT
9	20171	*	*	1	上軸メタル(中間)ゴム栓	RUBBER PLUG
10	18113	*	*	1	ビニールチューブ	OIL TUBE 35MM
11	18109	*	*	1	油芯	OILING WICK 220MM
12	18111	*	*	1	ビニールチューブ	OIL TUBE 75MM
13	18104	*	*	1	オイル上タンクフェルト	FELT
14	19106	*	*	1	オイル上タンク	OIL RESERVOIR
15	11044	*	*	1	オイル上タンク(右)止めねじ	SCREW 1/8X40 L=7.0
16	20171	*	*	1	上軸メタル(後)ゴム栓	RUBBER PLUG
17	11069	*	*	1	上軸メタル(後)フェルト	OILING FELT
18	20067	*	*	1	上軸油ゴム栓	RUBBER PLUG
19	18108	*	*	1	油芯	OILING WICK 160MM
20	11069	*	*	1	カマ軸メタル(前)フェルト	OILING FELT
21	18100	*	*	1	ビニールチューブ	OIL TUBE 80MM
22	18101	*	*	1	油芯	OILING WICK 180MM
23	18094	*	*	1	油調節押し板	OIL CONTROLLER
24	18093	*	*	1	油調節受板	OIL CONTROLLER PLATE
25	21104	*	*	1	油調節受板止めねじ	SCREW 11/64X40 L=7.5
26	18095	*	*	1	油調節ねじ	REGULATING SCREW M4X0.7 L=16.0
27	4137	*	*	1	油調節ねじナット	NUT M4X0.7
28	18354	*	*	1	オイル板パッキン	OIL RESERVOIR GASKET
29	19545	*	*	1	オイル板	OIL RESERVOIR PLATE
30	18353	*	*	1	オイル窓	OIL RESERVOIR WINDOW
31	15007	*	*	4	オイル板止めねじ	SCREW 9/64X40 L=10.0
32	18092	*	*	1	油栓パッキング	OIL PACKING
33	18091	*	*	1	油栓ねじ	SCREW 11/64X40

ACCESSORIES 付属品関係

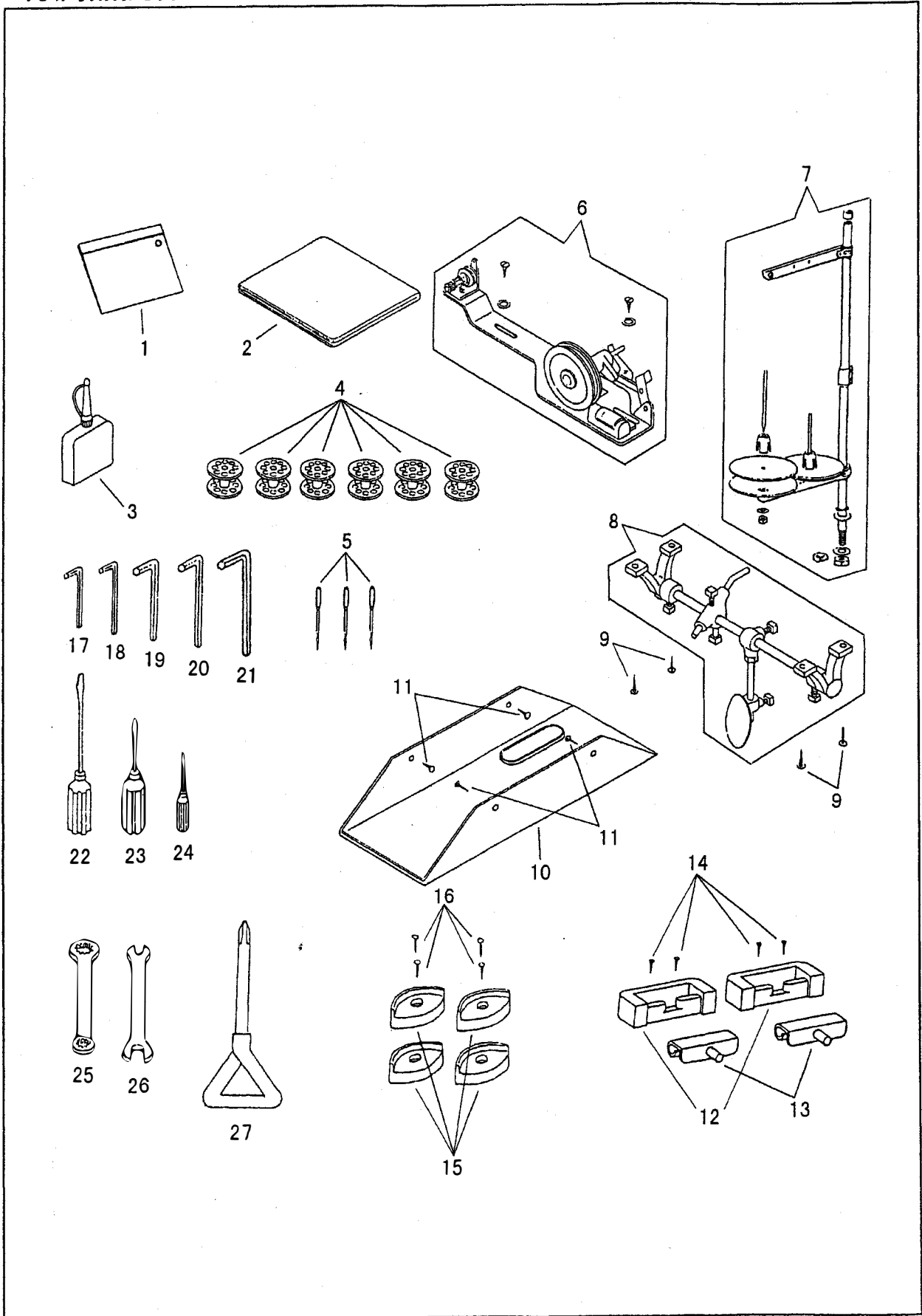

ACCESSORIES
 付属品関係

NO.	部品番号 PARTS NO.	STH-8BLD		QTY	品名	PARTS NAME
		-3	-2			
1	8132-B	*	*	1	部品袋	ACCESSORIES BAG
2	6057	*	*	1	ビニールカバー(小)	VINYL COVER
3	8123	*	*	1	油	OIL
4	18034	*	*	6	ボビン	BOBBIN
5	N0122	*	*	3	針 DP X 17 #22	NEEDLE DP X 17 #22
6	10734	*	*	1	糸巻セット	BOBBIN WINDER COMPLETE
7	35254	*	*	1	糸立セット	SPOOL PIN COMPLETE
8	19464	*	*	1	ひざ上げセット	KNEE LIFTER COMPLETE
9	19464-14	*	*	4	木ねじ(4.5 X 25L)	SCREW
10	6054	*	*	1	油受	OIL PAN COMPLETE
11	6055	*	*	4	油受止釘	NAIL
12	11886	*	*	2	ヒンジラバー	BED HINGE RUBBER
13	11885	*	*	2	ヒンジ	BED HINGE CONNECTION
14	6055	*	*	4	ヒンジラバー止釘	NAIL
15	11887	*	*	4	コーナーゴム	RUBBER
16	6055	*	*	4	コーナーゴム止釘	NAIL
17	19456	*	*	1	六角レンチ (2 MM)	WRENCH 2.0 MM
18	19457	*	*	1	六角レンチ (2.5 MM)	WRENCH 2.5 MM
19	19458	*	*	1	六角レンチ (3 MM)	WRENCH 3.0 MM
20	19459	*	*	1	六角レンチ (4 MM)	WRENCH 4.0 MM
21	19460	*	*	1	六角レンチ (5 MM)	WRENCH 5.0 MM
22	19466	*	*	1	ドライバー(大)	SCREW DRIVER (LARGE)
23	19467	*	*	1	ドライバー(中)	SCREW DRIVER (MIDDLE)
24	19468	*	*	1	ドライバー(小)	SCREW DRIVER (SMALL)
25	19462	*	*	1	メガネレンチ	DOUBLE HEAD WRENCH
26	19461	*	*	1	スパナ (6 X 7 MM)	SPANNER 6 X 7 MM
27	8180	*	*	1	十字ドライバー	SCREW DRIVER (+)

PARTS AVAILABLE AT EXTRA CHARGE
別売品

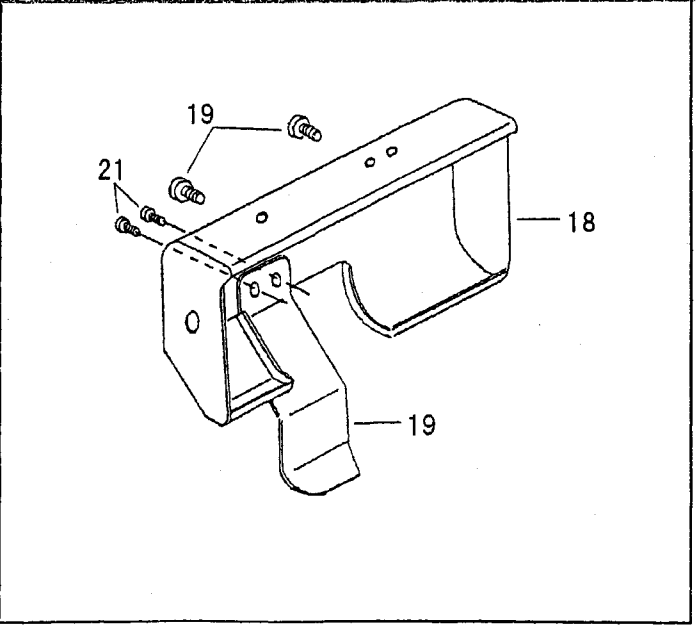
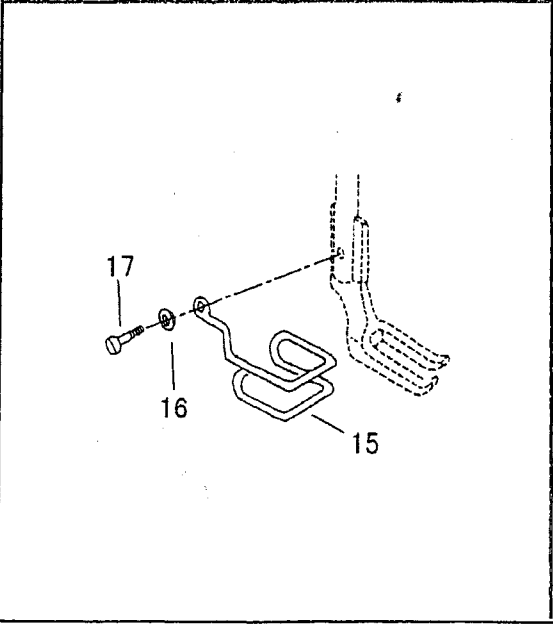
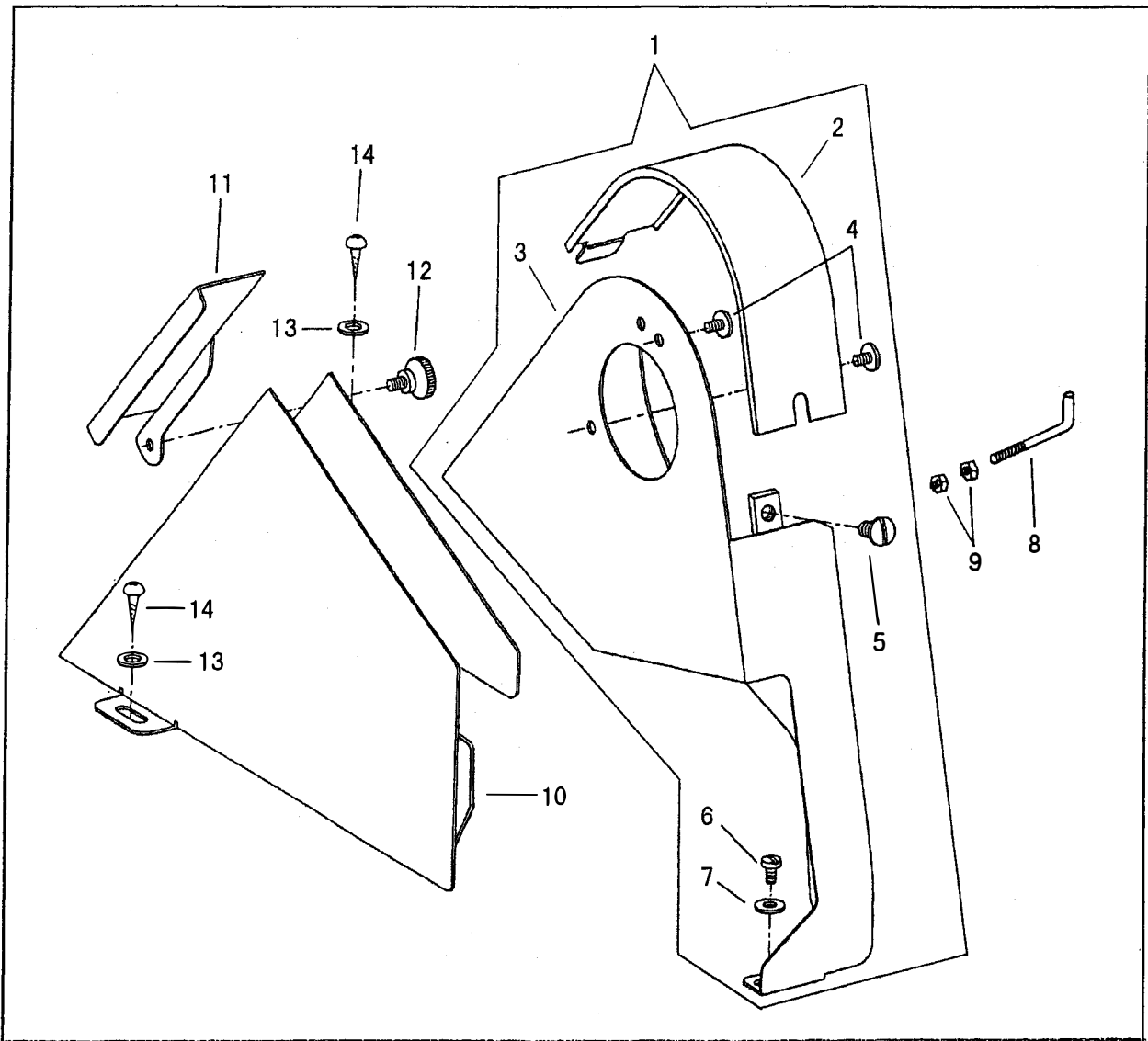

From the library of: Diamond Needle Corp

PARTS AVAILABLE AT EXTRA CHARGE
別売品

NO.	部品番号 PARTS NO.	STH-8BLD		QTY	品名	PARTS NAME
		-3	-2			
1	15098C	*	*	1	ベルトガード(組)	BELT GUARD SET
2	15099	*	*	1	ベルトガード上カバー	BELT GUARD UPPER COVER
3	15098	*	*	1	ベルトガード	BELT GUARD
4	8100	*	*	2	ベルトガード止めねじ	SCREW 9/64X40 L=6.5
5	12418	*	*	1	上カバー止めねじ	UPPER COVER SCREW 13/64X32 L=9.0
6	8100	*	*	1	ベルトガード止めねじ	SCREW (LOWER) 9/64X40 L=6.5
7	11142	*	*	1	ベルトガード止(下)ワッシャー	WASHER
8	17372	*	*	1	検出器支え棒	SYNCHRONIZER SUPPORT
9	50409	*	*	2	検出器支え棒止ナット	SYNCHRONIZER SUPPORT NUT
10	15121	*	*	1	補助ガード(大)	AUXILIARY BELT GUARD (LARGE)
11	15122	*	*	1	補助ガード(小)	AUXILIARY BELT GUARD (SMALL)
12	11830	*	*	1	補助ガード(小)止	SCREW 9/64X40 L=5.0
13	16287	*	*	2	補助ガード(大)止ワッシャー	WASHER
14	15081	*	*	2	補助ガード(大)木ねじ	SCREW
15	10937	*	*	1	フィンガーガード	FINGER GUARD
16	10677	*	*	1	ワッシャー	WASHER
17	18484	*	*	1	止めねじ	SCREW 9/64X40 L=11.0
18	18469	*	*	1	横軸カバー	ROCK SHAFT COVER
19	37136	*	*	2	横軸カバー止めねじ	SCREW M5X0.8 L=10
20	18469-02	*	*	1	横軸カバー(下)	ROCK SHAFT COVER (LOWER)
21	6333	*	*	2	横軸カバー(下)止めねじ	SCREW 9/64X40 L=6.5

Consolidated Sewing Machine Corp.

MAIN OFFICE

131 West 25th Street
New York, NY 10001
Tel: (212) 741-7788
Fax: (212) 741-7787

BRANCH OFFICE

7855 NW 29th Street, Bay 166
Miami, FL 33122
Tel: (305) 471-0200
Fax: (305) 471-0243